

TRANSPRO↓AUTO

SELECT

HEAT PRESS USER'S GUIDE

MP885/MP887

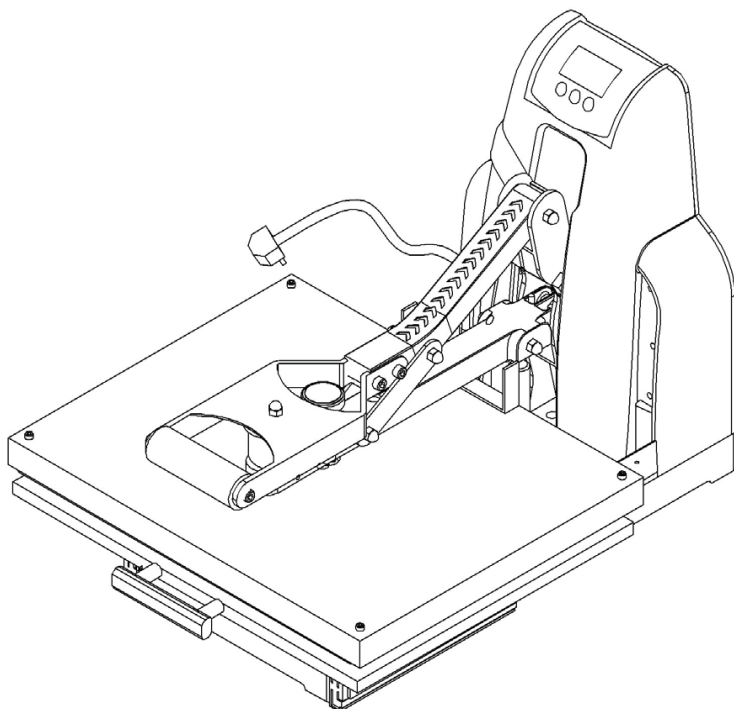

PRO WORLD[®]
HEAT APPLIED GRAPHICS • PRESSES • ACCESSORIES

www.ProWorldInc.com

Pro World Inc.
961 Bethel Ave.
Pennsauken, NJ 08110

Toll Free 800-678-8289
Outside U.S. 856-406-1020
Fax 856-406-1025

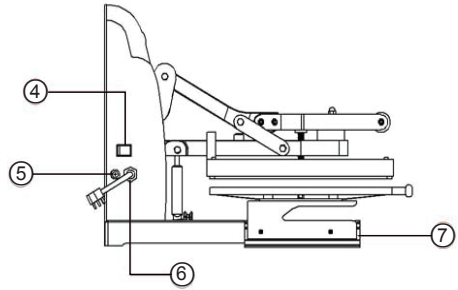
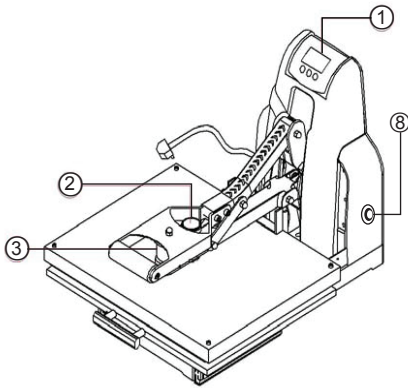

- | | | | |
|----------------------------|------------------------|-----------------|----------------------|
| ① GY-04 Digital Controller | ② Pressure Adjust Knob | ③ Electromagnet | ④ Power Switch |
| ⑤ Fuse | ⑥ Power Cord | ⑦ Machine base | ⑧ Emergency Shut Off |

Technical Parameters

1. Model No.: TransPro Auto Select MP885 and MP887
2. Heat Platen Size: 15"x15" or 16"x20"
3. Voltage: 110V
4. Power: 110V
5. Gross Weight: 65lbs and 95lbs

Connecting Your Heat Press To An Electrical Outlet

- Connect the power cord into a properly grounded electrical outlet with a sufficient amperage rating.
- Your Pro World Heat Press requires a full 15 amp grounded circuit for 120 vold operation.
- Extension cord use on the heat transfer machines is not recommended.
- Extension cords, if used, should be as short as possible and not less than 12 gauge. Heavy duty extension cords are highly recommended in this case.

Failure To Follow These Instructions Can Cause:

1. Erratic controller functions.
2. Inaccurate displays and slow heat-up.
3. The fuse to pop/break
4. Internal malfunctions prevent the machine from performing properly.

Instructions

1. Open the machine. The press will heat up automatically to the pre-set temperature.
(Normal pre-set temp is 350°F or 180°C)

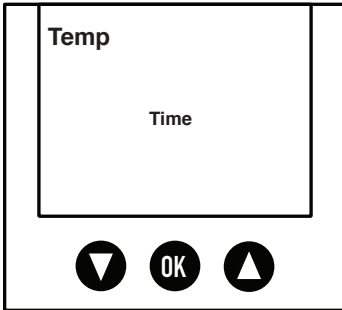

2. Press **OK** button to enter a setting for temperature. Then press **▲** or **▼** to switch to Fahrenheit or Celsius.

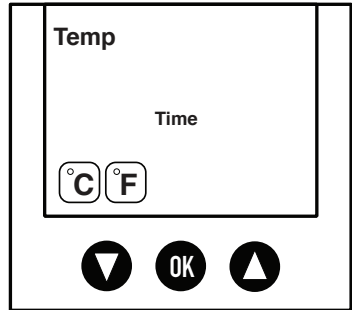

3. After setting to Fahrenheit or Celsius, press **OK** button to enter temperature.
(Fahrenheit: 0-446°F / Celsius: 0-230°C)

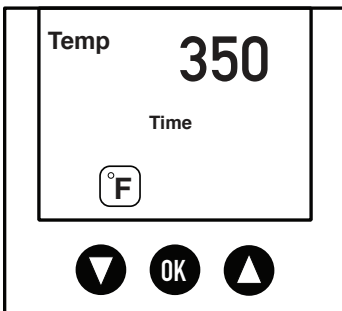

4. After temp setting, press the **OK** button to enter time setting. After time and temp is set. Press the **OK** button, and the machine will start heating.

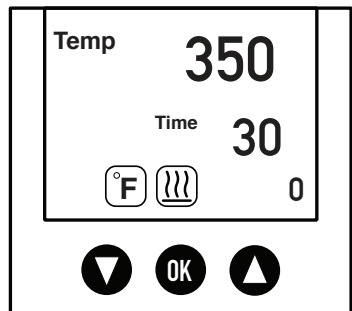

NOTE:

- 1) Please switch off the machine and unplug the power cord when the machine is not in use.
- 2) The heat platen will cool down to room temperature if heat press stays unused for more than 30 minutes.
- 3) For better maintenance of the heat press, the maximum temperature used should be 410 degrees F.
- 4) When printing double sided T-Shirts, insert a teflon sheet in between the shirt to protect the ink.
- 5) Heat platen may pivot slightly back and forth. This is due to movement allowance within the assembled clamp, and is normal.

IV. Troubleshooting

1. Machine will not power on.

- A). Check the plug to make sure it is connected to a grounded wall socket.
- B). Check the power switch or digital controller.
- C). Check the fuse to make sure it is not burnt out.
- D). Indicating light is on, but no display on screen, check the 5 cable of Railway transformer. If it is loose, the problem may be a poor connection.

2. The display screen is working well, but the temperature does not increase on the heat platen.

- A). Check if the indicating light of solid-state relay is on.
- B). If you already changed the new solid-state relay but the heat platen will not heat up, check if the heat platen power cable is loose.

3. The heat platen works well, but suddenly the display screen show 437°F.

- A). Check whether the thermocouple of the heat platen is connected firmly.

4. The machine is heating up, but the temperature jumps to above 437°F or 572°F or the temperature jumps irregularly.

- A). Check whether the thermocouple of the heat platen is connected firmly.

5. The temperature is out of control: Set 356°F, but the actual temperature is above 392°F.

- A). Relay may need to be changed.
- B). Or the digital controller may need to be changed.

If you need further assistance, please kindly contact Pro World for support: 800-678-8289

WIRING SCHEMATIC

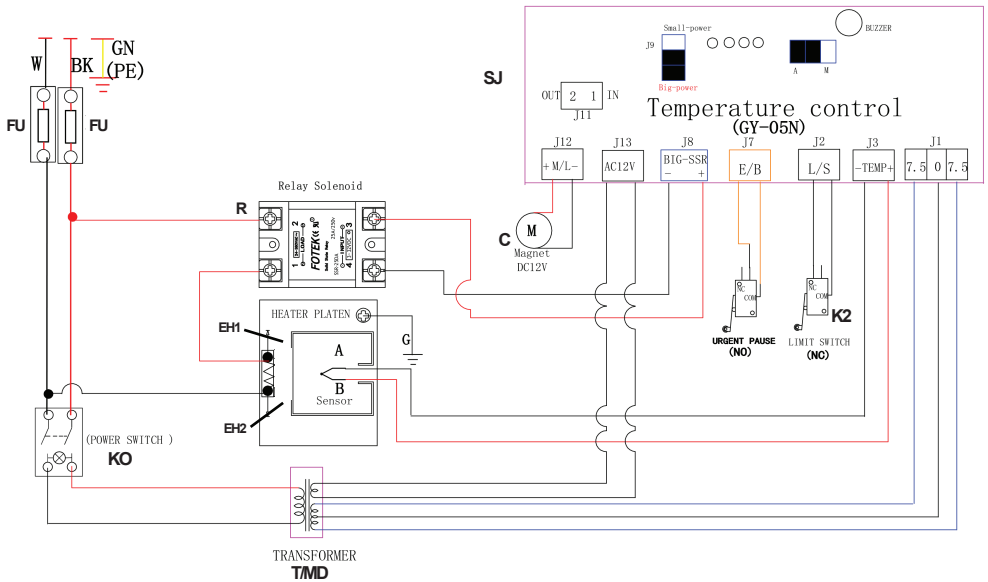

KO: Power Switch
 EH1 EH2: Heating Pipe
 T: Transformer

K2: Limit Switch
 SJ: Thermostat
 R1: Relay

FU: Fuse(16A/25V)
 C: Magnet
 MD : Magnet Driver

TRANSPRO WARRANTY

Warranty Coverage

TransPro products offered by Pro World are warranted against defects in material and workmanship. Warranty is void if equipment has been damaged by accident, unreasonable use, neglect, unauthorized and/or improper service, or other causes not arising out of defects in material and workmanship. This warranty does not cover damage caused by normal wear and tear, neglect or lack of proper maintenance. This warranty is for the original purchaser/owner only, it is not transferable.

Warranty Duration

The heating element shall be warranted for the life of the heat press. There is a one (1) year warranty on major components, circuit boards and all other components.

Warranty Performance

During the warranty period, and in the event that a situation cannot be resolved by telephone/email and upon PRE-AUTHORIZATION from Pro World equipment must be shipped, freight prepaid to Pro World for service in the original packaging. After 30 days, all shipping and insurance expenses to and from Pro World of in-warranty equipment is solely the responsibility of the customer. Prior to 30 days the shipping costs will be refunded if Pro World deems the equipment to be defective as stated. Pro World cannot be held responsible for improper handling or any other damage incurred in transit. No charge will be made for labor and components for repair of in-warranty equipment. OUT-OF WARRANTY machines will be charged at the repair rates in effect at the time the machine is received.

Warranty Disclaimers

Pro World shall not be liable for loss of use of TransPro equipment or other incidental or consequential costs, expenses, or damages incurred by the original purchaser or any other user. The above warranty provisions constitute the entire agreement between all parties, and supersede any and all prior written and/or oral representations and understandings.

This "Limited Warranty" applies to all TransPro equipment. However, the procedure for obtaining service may vary outside the continental United States. Contact your Pro World representative for warranty information. The purchaser is responsible for compliance with all local laws, regulations and measure. Agreement shall be governed by and construed in accordance with all applicable laws of said region.



www.ProWorldInc.com

Pro World Inc.
961 Bethel Ave.
Pennsauken, NJ 08110

Toll Free 800-678-8289
Outside U.S. 856-406-1020
Fax 856-406-1025